



PRODUCT SPECIFICATIONS

Module No.: NTD-5.0T800480R100D

TFT(Thin-Film-Transistor) Color Liquid Crystal Display Module

General Specification

- 5.0 inch Diagonal
- 800xRGBx480 resolution
- 24 bit RGB interface
- LED Backlight (500cd/m²)
- 16.7 M colors Normally Black
- 12:00 O'clock Optimal View
- **RoHS Compliant**

For Customer's Acceptance:

Approved By	Comment

From: NewTrend Display Technology Co., Ltd.

--

Outline Drawing

SYMBOL	REVISION	DATE
V0	First	

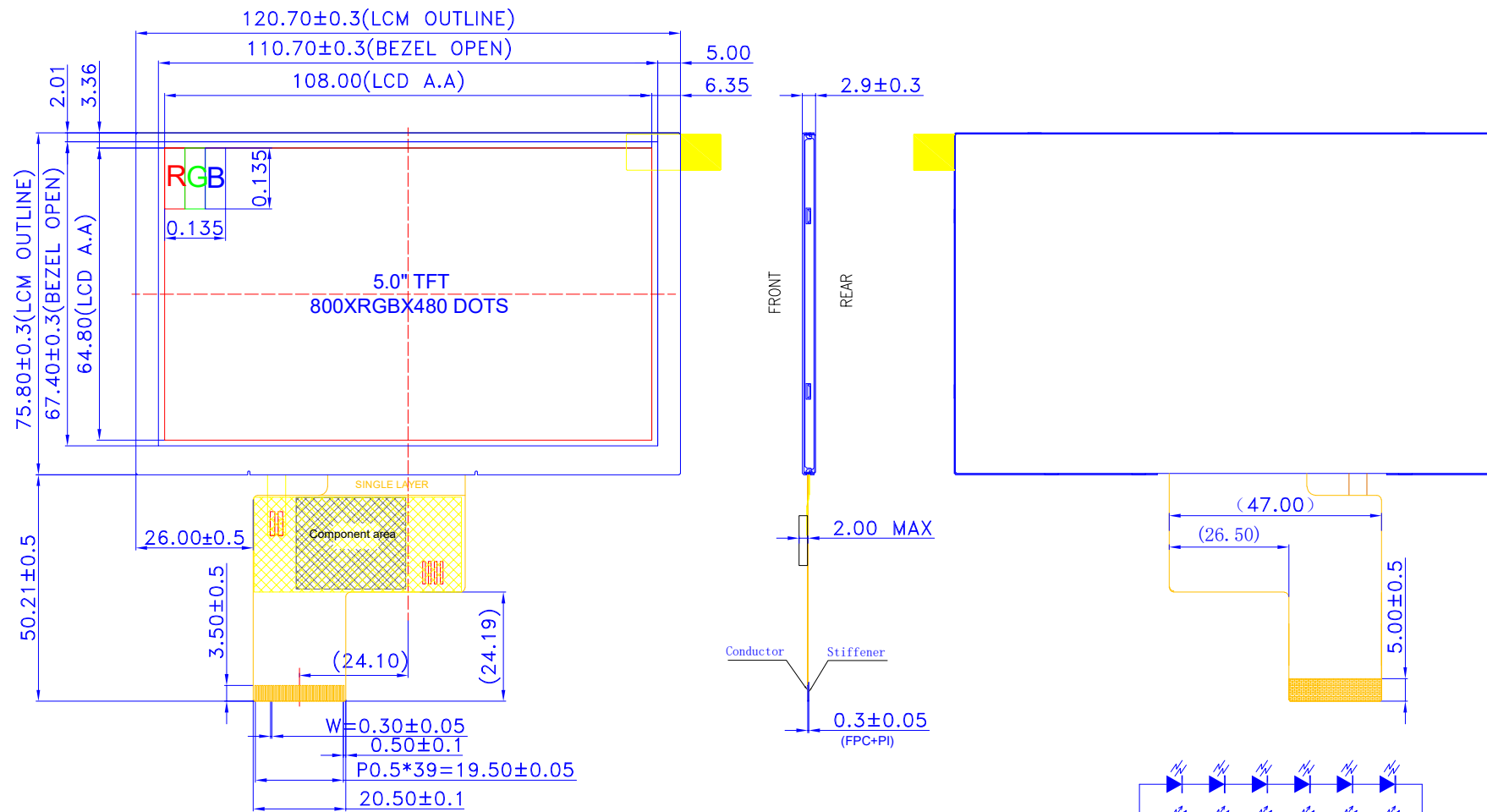

PIN	SYMBOL
1	LEDK
2	LEDA
3	GND
4	VDD
5	R0
6	R1
7	R2
8	R3
9	R4
10	R5
11	R6
12	R7
13	G0
14	G1
15	G2
16	G3
17	G4
18	G5
19	G6
20	G7
21	B0
22	B1
23	B2
24	B3
25	B4
26	B5
27	B6
28	B7
29	GND
30	PCLK
31	DISP
32	HSYNC
33	VSYNC
34	DE
35	NC
36	GND
37	NC
38	NC
39	NC
40	NC

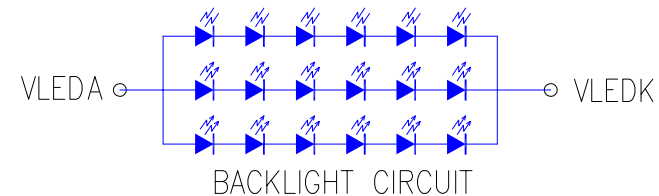

NOTES:

1. DISPLAY TYPE: 5.0" TFT, Transmissive, Normally White
2. OPTIMUM VIEWING : 12:00
3. Top: -20°C~+70°C, Tst: -30°C~+80°C
4. TFT Interface :24-bit RGB Interace, VDD=3.3±0.3V
5. LCM Luminance:LED/500cd/m (TYP)² IF=60mA,VF=18V(TYP)
6. RoHS

UNLESS OTHERWISE SPECIFIED Unit:mm THIRD ANGLE PROJECTION:		NewTrend Display Technology	
UNLESS OTHERWISE NOTED TOLERANCES :±0.2mm		DRAWING_NO. NTD-5.0T800480R100D	
SCALE	SHEET	DRAWN BY:	APPROVED BY:
1:1	1 OF 1		

Pin Description:

Pin No.	Symbol	Function Description	Remark
1	LEDK	LED backlight (Cathode).	
2	LEDA	LED backlight (Anode).	
3	GND	Ground.	
4	VDD	Power supply.	
5	R0	Red Data Input	
6	R1	Red Data Input	
7	R2	Red Data Input	
8	R3	Red Data Input	
9	R4	Red Data Input	
10	R5	Red Data Input	
11	R6	Red Data Input	
12	R7	Red Data Input	
13	G0	Green Data Input	
14	G1	Green Data Input	
15	G2	Green Data Input	
16	G3	Green Data Input	
17	G4	Green Data Input	
18	G5	Green Data Input	
19	G6	Green Data Input	
20	G7	Green Data Input	
21	B0	Blue Data Input	
22	B1	Blue Data Input	
23	B2	Blue Data Input	
24	B3	Blue Data Input	
25	B4	Blue Data Input	
26	B5	Blue Data Input	
27	B6	Blue Data Input	
28	B7	Blue Data Input	
29	GND	Ground.	
30	DCLK	Clock Input	
31	DISP	Display on/off	
32	HSYNC	Horizontal sync input in RGB mode.	
33	VSYNC	Vertical sync input in RGB mode.	
34	DE	Data enable input. Active high to enable the input data bus.	
35	NC	No connection	
36	GND	Ground.	
37	NC	No connection.	
38	NC	No connection.	
39	NC	No connection.	
40	NC	No connection.	

DC Electrical Characteristics

Item	Symbol	Condition	Min.	Typ.	Max.	Unit
Operating Temperature Range	Top	Absolute Max	-20	-	+70	°C
Storage Temperature Range	T _{ST}	Absolute Max	-30	-	+80	°C
Digital Supply Voltage	V _{DD}	-	3.0	3.3	3.6	V
Analog Supply Voltage	I _{DD}	-	-	7.0	10	V
I/O Leak Current	I _{LI}	-	-1	-	1	uA
Input logic high voltage	V _{IH}	-	0.7*V _{DD}	-	V _{DD}	V
Input logic low voltage	V _{IL}	-	GND	-	0.3*V _{DD}	V
Output High Voltage	V _{OH}	-	V _{DD} -0.4	-	V _{DD}	V
Output Low Voltage	V _{OL}	-	GND	-	GND+0.4	V

Note 1: Please adjust VCOM to make the flicker level be minimum. Typ VCOM Voltage value is only for reference, subject to the actual effect (adjustable according to FLICKER status)

Item	Symbol	Condition	Min.	Typ.	Max.	Unit
Backlight Supply Voltage	V _f	Top=25°C I _f =60mA	15.6	18.0	20.4	V
Backlight Supply Current	I _f		-	60		mA
Backlight Lifetime	-	Top=25°C I _f =60mA	30000			Hrs

*Backlight lifetime is rated as Hours until half-brightness, under normal operating conditions. The LED of the backlight is driven by current drain, drive voltage is for reference only. Drive voltage must be selected to ensure backlight current drain is below MAX level stated.

Optical Characteristics

Item	Symbol	Condition	Min.	Typ.	Max.	Unit	
Operating Viewing Angles	Top	-	CR≥10	50	-	Deg	
	Bottom	-		70	-		
	Left	-		70	-		
	Right	-		70	-		
Contrast Ratio	CR	Center	800	1000	-	-	
Luminance	L _v		450	550		cd/m ²	
Response Time	T _r +T _f			35	50	ms	
Chromaticity	Red	X _R	-	TYP-0.05	TBD	TYP+0.05	-
		Y _R			TBD		
	Green	X _G	-		TBD		
		Y _G			TBD		
	Blue	X _B	-		TBD		
		Y _B			TBD		
	White	X _w	-		TBD		
		Y _w	-		TBD		

Note (1) Measurement Setup: The LCD module should be stabilized at given temp. 25°C for 15 minutes to avoid abrupt temperature change during measuring. In order to stabilize the luminance, the measurement should be executed after lighting backlight for 15 minutes in a windless room.

Power ON/OFF Sequence

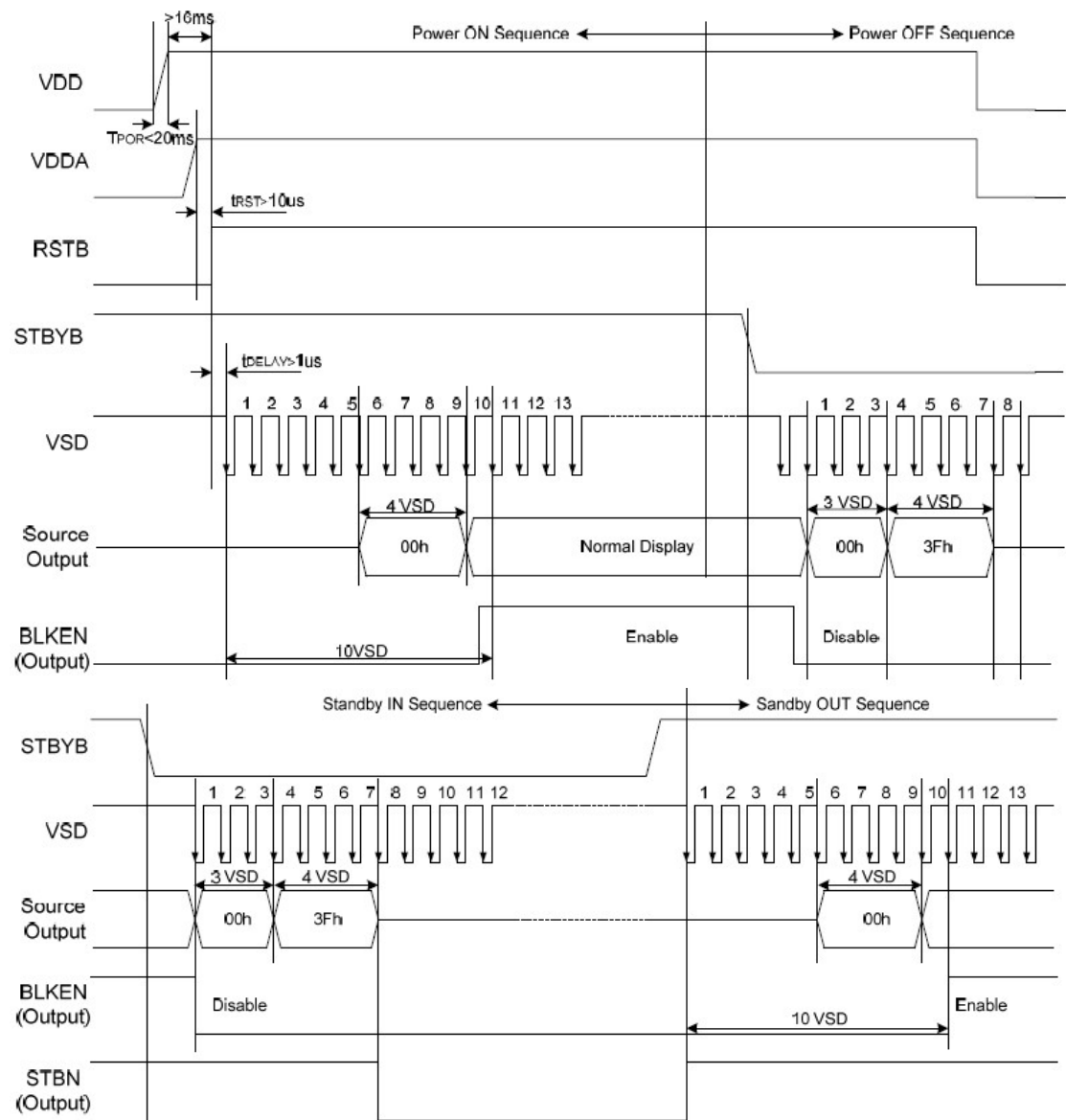

Power on sequence (VDD→VEE→VGH)

AC Electrical characteristics

DE Mode (MODE='1')

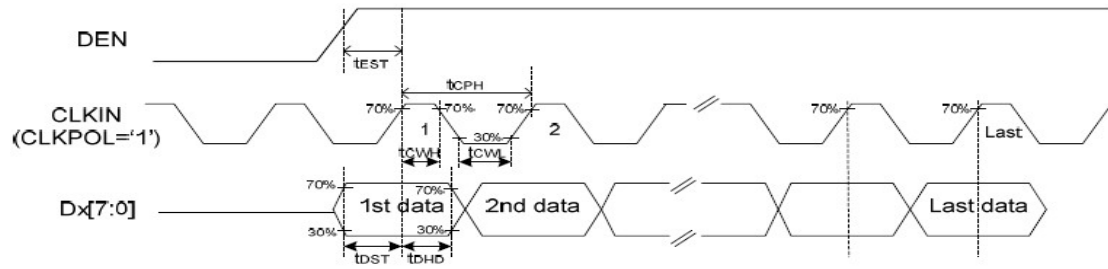

SYNC Mode (MODE='0')

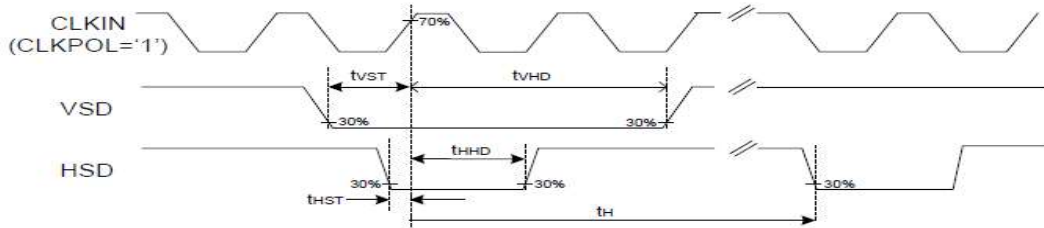

Source Output timing Diagram (Cascade)

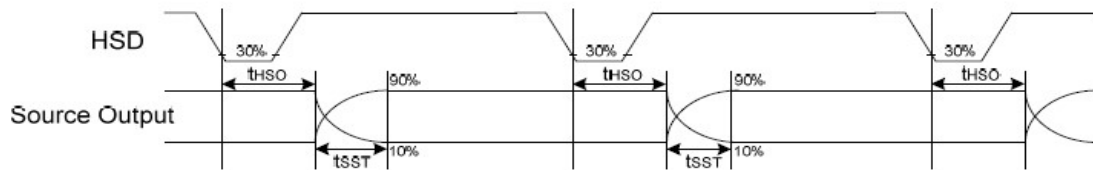

Vertical Timing Diagram of SYNC Mode (Dual Gate)

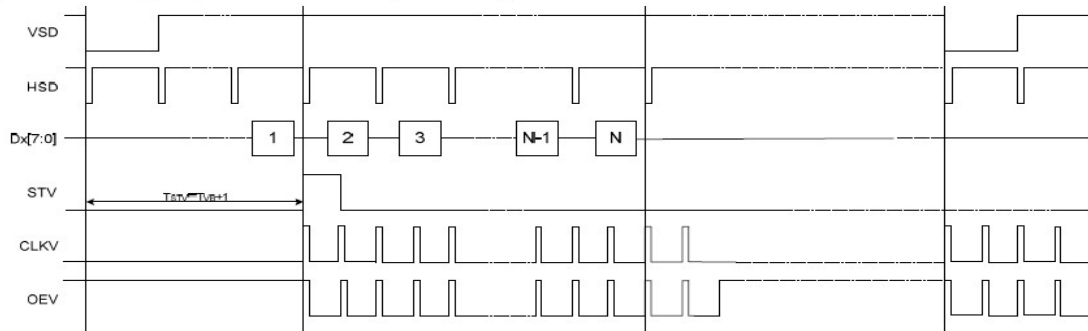

Vertical Timing Diagram of DE Mode (Dual Gate)

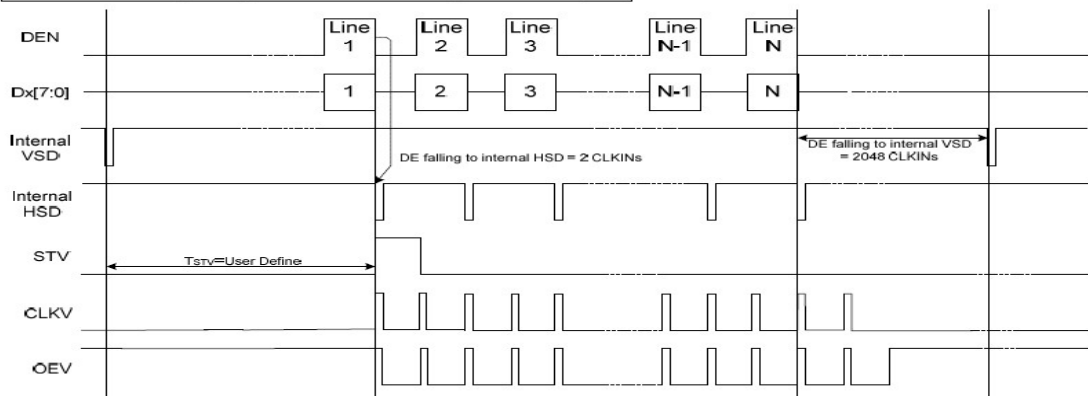

Display Timing characteristics(Resolution: 800x480)

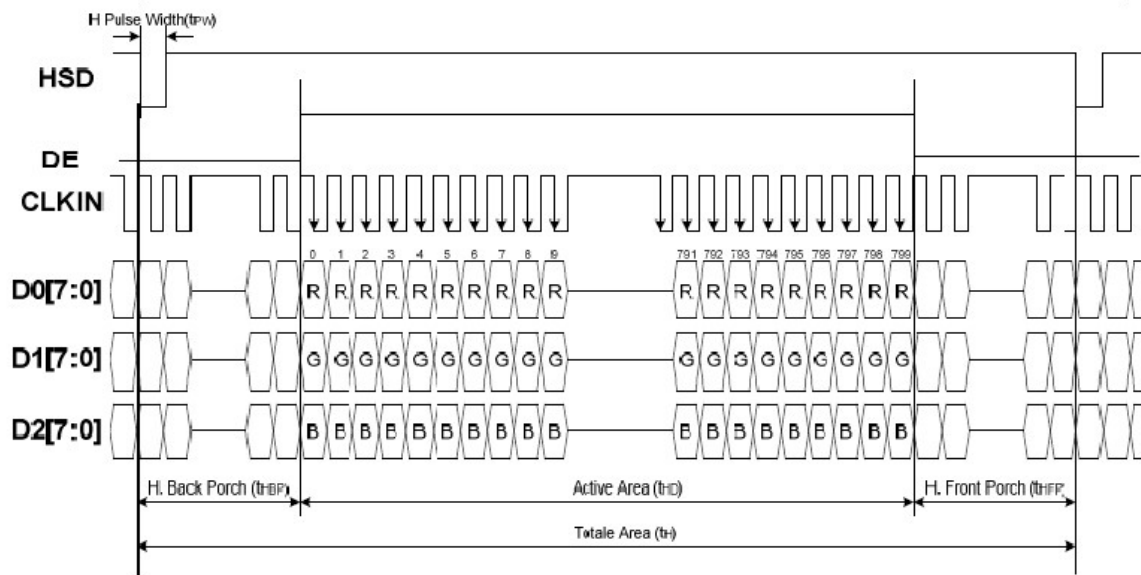

Horizontal Input Timing						
Parameter	Symbol	Value			Unit	
		Min.	Typ.	Max.		
Horizontal display area	t_{HD}	--	800	--	CLKIN	
CLKIN frequency	f_{CLK}	--	33.3	50	MHz	
1 Horizontal line period	t_H	862	1056	1200	CLKIN	
HSD pulse width	t_{HPW}	Min.	--	1	CLKIN	
		Typ.	--	--	CLKIN	
		Max.	--	40	CLKIN	
HSD back porch	SYNC	t_{HBP}	46	46	46	CLKIN
HSD front porch	SYNC	t_{HFP}	16	210	354	CLKIN

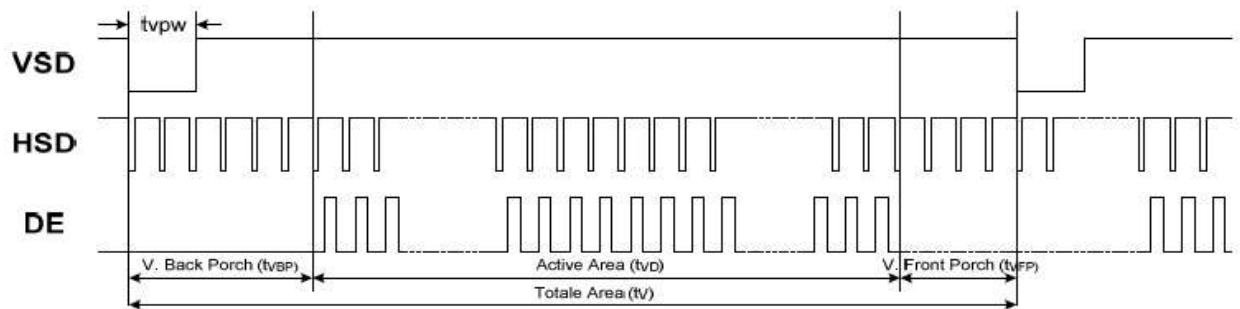

Vertical Input Timing					
Parameter	Symbol	Value			Unit
		Min.	Typ.	Max.	
Vertical display area	t_{VD}	--	480	--	HSD
VSD period time	t_V	510	525	650	HSD
VSD pulse width	t_{VPW}	1	--	20	HSD
VSD back porch	t_{VBP}	23	23	23	HSD
VSD front porch	t_{VFP}	7	22	147	HSD

Reliability Test Items and Criteria

No	Test Item	Test condition	Criterion
1	High Temperature Storage	80°C±2°C 96H Restore 4H at 25°C , Power off	1. After testing, cosmetic and electrical defects should not happen. 2. Total current consumption should not be more than twice of initial value.
2	Low Temperature Storage	-30°C±2°C 96H Restore 4H at 25°C , Power off	
3	High Temperature Operation	70°C±2°C 96H Restore 4H at 25°C , Power on	
4	Low Temperature Operation	-20°C±2°C 96H Restore 4H at 25°C , Power on	
5	High Temperature/Humidity Storage	50°C±2°C 90%RH 96H Power off	
6	Temperature Cycle	$\begin{array}{ccccccc} -30^{\circ}\text{C} & \rightarrow & +25^{\circ}\text{C} & \rightarrow & 80^{\circ}\text{C} & \rightarrow & +25^{\circ}\text{C} \\ (30\text{mins}) & & (5\text{mins}) & & (30\text{mins}) & & (5\text{mins}) \\ \leftarrow & & & & & & \rightarrow \\ & & & & \text{5 Cycle} & & \\ \text{Restore 4H at 25}^{\circ}\text{C} , & & & & & & \text{Power off} \end{array}$	

Precautions for Use of LCD Modules

1. Handling Precautions

1.1 The display panel is made of glass. Do not subject it to a mechanical shock by dropping it from a high place, etc.

1.2 If the display panel is damaged and the liquid crystal substance inside it leaks out, be sure not to get any in your mouth, if the substance comes into contact with your skin or clothes, promptly wash it off using soap and water.

1.3 Do not apply excessive force to the display surface or the adjoining areas since this may cause the color tone to vary.

1.4 The polarizer covering the display surface of the LCD module is soft and easily scratched. Handle this polarizer carefully.

1.5 If the display surface is contaminated, breathe on the surface and gently wipe it with a soft dry cloth. If still not completely clear, moisten cloth with one of the following solvents:

- Isopropyl alcohol
- Ethyl alcohol

Solvents other than those mentioned above may damage the polarizer. Especially, do not use the following:

- Water
- Ketone
- Aromatic solvents

1.6 Do not attempt to disassemble the LCD Module.

1.7 If the logic circuit power is off, do not apply the input signals.

1.8 To prevent destruction of the elements by static electricity, be careful to maintain an optimum work environment.

- a. Be sure to ground the body when handling the LCD Modules.
- b. Tools required for assembly, such as soldering irons, must be properly ground.
- c. To reduce the amount of static electricity generated, do not conduct assembly and other work under dry conditions.
- d. The LCD Module is coated with a film to protect the display surface. Be care when peeling off this protective film since static electricity may be generated.

2. Storage precautions

2.1 When storing the LCD modules, avoid exposure to direct sunlight or to the light of fluorescent lamps.

2.2 The LCD modules should be stored under the storage temperature range. If the LCD modules will be stored for a long time, the recommend condition is:

Temperature : 10°C ~ 40°C

Relatively humidity: ≤60%

2.3 The LCD modules should be stored in the room without acid, alkali and harmful gas.

3. The LCD modules should be no falling and violent shocking during transportation, and also should avoid excessive press, water, damp and sunshine.